



Model Number:	SD3-286T-4-BR-E-30
MFG PN:	4158
List Price:	

All data shown at HIGH voltage setting

Format: STD 3 Phase

Electrical Data				General Data		
Rated Motor Output Power	30.0	HP		Frame Size	286T	
Rated Motor Speed	1770	r/min 60Hz		Enclosure	TEFC	
	1450	r/min 50Hz		Mounting	Rigid	
Rated Motor Voltage (3 Phase)	460	V/60Hz		NEMA Design	B	
	380	V/50Hz		IP Rating	55	
Rated Motor Current	35.3	A (In) @ 60Hz		Insulation Class	F	
	43	A (In) @ 50Hz		Tropicalization	1	
FL Current @ 208V	None	A (In) @ 60Hz		Duty	Cont.	
Service Factor	1.25	@ 60Hz		Cable Entry	None	
	1.25	@ 50Hz		Feet Removable	0	
KVA Code	G	60Hz		Double Drilled	0	
	D	50Hz		Frame Material	Cast	
Nominal Efficiency	93.6	% @ 60Hz		Shaft Material	None	
	90.4	% @ 50Hz		Coating	RAL	7024
Nominal Power Factor	0.85	cosθ @ 60Hz				
Full Load Torque Ft-Lb	S			Mechanical Data		
Load Data	Trq Ft-Lb	Trq %FL	Current Amps	Bearing DE Side	6311	
Locked Rotor				Bearing NDE Side	6311	
Breakdown	520.1133389	220.0	-	Comp Ring (wavey washer)	DE	
Pull Up	333.7535106	197.0	-	Weight	600.8625	Lbs
Load Data	RPM	Eff %	Current Amps	Moment of Inertia	None	kg.m3
125% of FL	1774.4	93.41	82.79	Site Conditions		
75% of FL	1785.5	94.29	52.63	Temp Rise @ Full Load °C	None	@ 60Hz
50% of FL	1790.5	93.78	40.19	Ambient Temperature °C	40	
No Load	1199.0	0	26.53	Altitude Above Sea Level (M)	1000	
Brake Torque (N-M)	100.0	Loaded Torque Curves		None		
Brake Coil Voltage	None	P1 = Output Power (KW), S = Slip (% of Sync RPM), η = Efficiency (%), cosφ = Power Factor				

CT VFD Range	
Haz Loc Rating	
Options:	
UL File Number	
CSA File Number	
DOE File Number	
CE APPROVAL	
Wiring Diagram	NEMA-3-6-D

Techtop Industries -2815 Colonnades Court - Peachtree Corners, GA 30071 - Phone: (678) 436-5540



Model Number:	SD3-286T-4-BR-E-30
MFG PN:	
List Price:	4158

Dimensional Drawing (For Reference Only)

841-286T30U4B

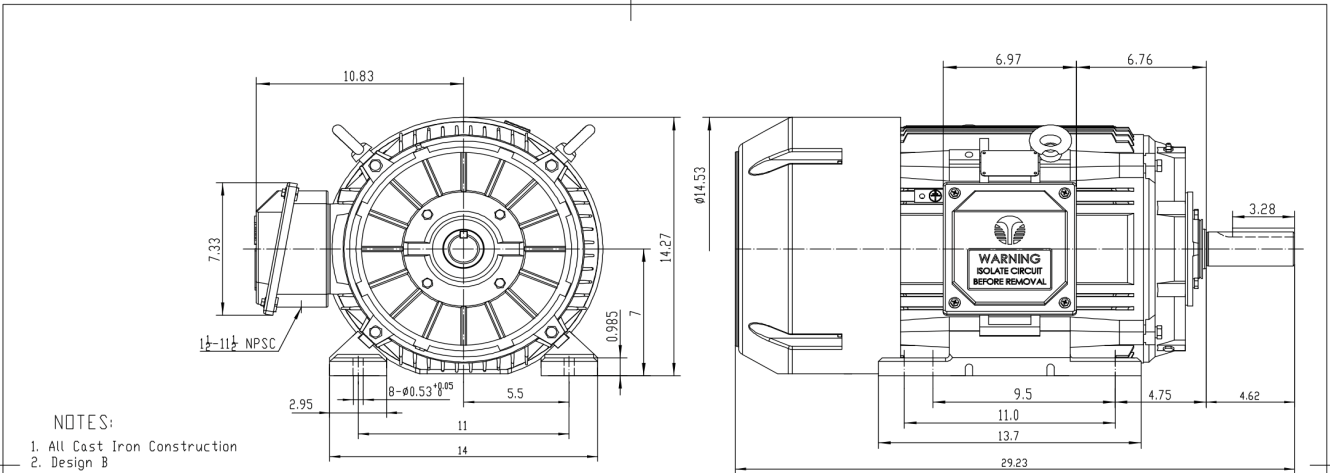

NOTES:

- All Cast Iron Construction
- Design B
- IP55 Labyrinth seals on DE and ODE
- H Class Insulation System
- Max Winding Temperature rise 80°C
- Max bearing temperature rise 45°C for 4 pole and 50°C for 2 pole motors when direct coupled.
- Regreaseable bearings
- External Grounding provisions
- Maximum foot flatness deviation .127 mm
- Conductive Polymer Cooling Fan
- Diagonally Split Conduit Box rotatable in 90° Increments
- Lead seals in conduit box
- Maximum no load sound power 85 dBA(2 pole), Maximum no load sound power 70 dBA(4 pole), Maximum no load sound power 64 dBA(6 pole).
- No Load Motor Vibration not to exceed
 - Radial 60HZ - 2.03mm/s (2,4 pole) and 1.52mm/s (6 pole)
 - Axial 60HZ - 1.52mm/s
- 300 series Stainless Steel hardware
- Epoxy Coating meeting ASTM B117-97 for 96 h
- All internal surfaces coated with anti-corrosion coating.
- Internal Shaft Grounding brush installed on drive end.
- No Load test report included with motor

TECHTOP IEEE 841 SEVERE DUTY ELECTRIC MOTOR	
MODEL: SD3-286T-4-BR-E-30	TECHTOP.COM
NEMA 30 30 SER # T286T30U4B	
HP 1770 1450 DATE 06/28/2022	
RPM 450 380 DESIGN B	
VOLT(3Ø) 35.3 43.0 FRAME 286T	
SF 1.25 1 ENCL TEFC	
KVA CODE G D DUTY Cont.	
NOM EFF 0.936	
ARC ARRESTOR	
VFD 15:1 CT-1.0 SF	
WEIGHT 426 lbs	
MADE IN CHINA	

CONNECTIONS

T1 T2 T3

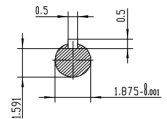

 ShangHai HIMAK Electrical Machinery CO., LTD		NEMA TEFC 286T-30HP-4P	
		IEEE-841 UNITS:INCHN	
Design		NO:	CY256.A20.005
Checker		STEP MARK	1:4.5 SORT Cast iron Motor
Auditing		Date	

Components

Item	Model	Description	List Price
C-Face Kit			
D-Flange Kit			
DE Endplate Kit			
NDE Endplate Kit			
Junction Box			
Cooling Fan Cover			
Cooling Fan			
Replacement Feet			
DE Bearing Retainer Kit			
NDE Bearing Retainer Kit			

